



# Next-Generation Automatic Volume Control for Mobile Phones

Presented at:

**IEEE Comm. Society & Sig. Proc. Society  
Joint Meeting, National University, San Diego, CA**

Presented by:

**Franklin Felber  
Starmark, Inc., San Diego, CA**

**26 May 2011**

[www.StarmarkTechnologies.com](http://www.StarmarkTechnologies.com)





# Summary

- **Problem**

**Noise interferes with speech intelligibility**  
- In cars, crowds, outdoors

- **Solution**

**SmartAVC™ maintains constant intelligibility**

[www.StarmarkTechnologies.com](http://www.StarmarkTechnologies.com)





# **SmartAVC™ Unique Features**

- **Weights noise in frequency domain**
  - **Calculates PSIL for intelligibility**
- **Filters noise in time domain ~ 1/4 sec**
- **Smooths fluctuations – graceful volume control**
- **Finds minimum-volume preference**

[www.StarmarkTechnologies.com](http://www.StarmarkTechnologies.com)





# Technology

- **SmartAVC™** is set of algorithms
  - software or hardware on chips or DSPs
    - US Pat. 7,760,893 – July 2010
    - US Pat. 7,908,134 – March 2011
    - Int'l. patents pending
- **SmartAVC™** available as Android demo app

[www.StarmarkTechnologies.com](http://www.StarmarkTechnologies.com)





# Conventional AVC

- Automatic volume controls in
  - Mobile phones – Nokia Voice Clarity, LG Voice Clarity, Motorola CrystalTalk<sup>®</sup>, ...
  - Bluetooth headsets – Jabra, BlackBerry, ...
  - Car radios (speed-dependent) – Alpine, ...
  - TVs (for commercials)
- Work poorly or not at all – all ‘Default Off’

[www.StarmarkTechnologies.com](http://www.StarmarkTechnologies.com)





# AVC Smartness Scale

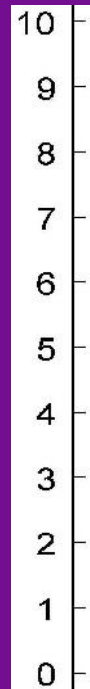

Constant Intelligibility – *SmartAVC™* patents, 2010 and 2011

Speech-Interference Noise Level

Perceived Noise

Total Noise

Constant  $S/N_A$  – Nokia patent, 1999

Constant  $S/N$  – AMD patent, 1997

Manual S

Constant S – Loud Signal

[www.StarmarkTechnologies.com](http://www.StarmarkTechnologies.com)





# SmartAVC™ Advantages

## Conventional AVC

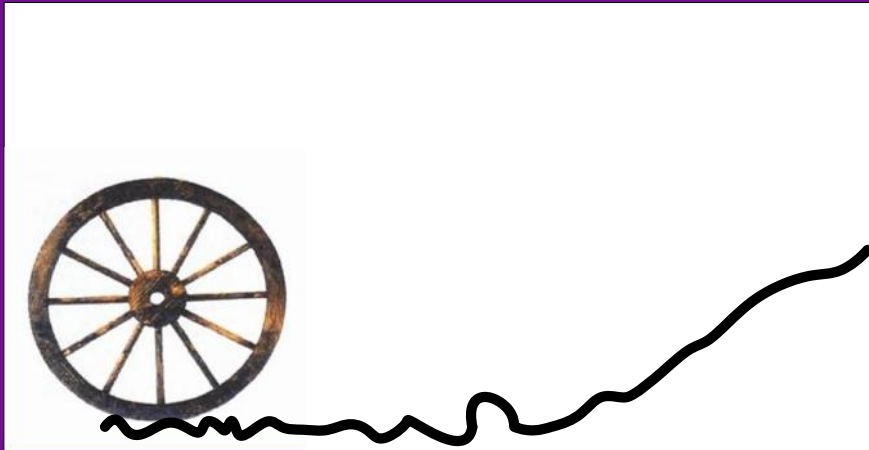

Preserves S/N

[www.StarmarkTechnologies.com](http://www.StarmarkTechnologies.com)





# SmartAVC™ Advantages

## Conventional AVC

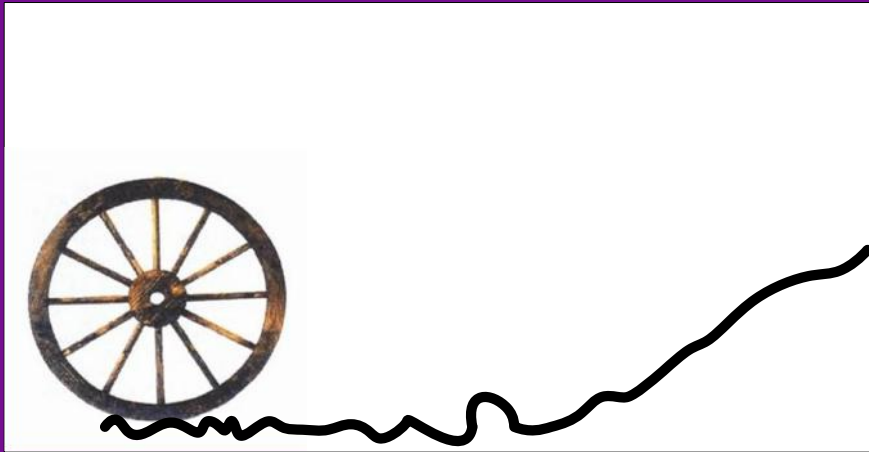

### Preserves S/N

## SmartAVC™

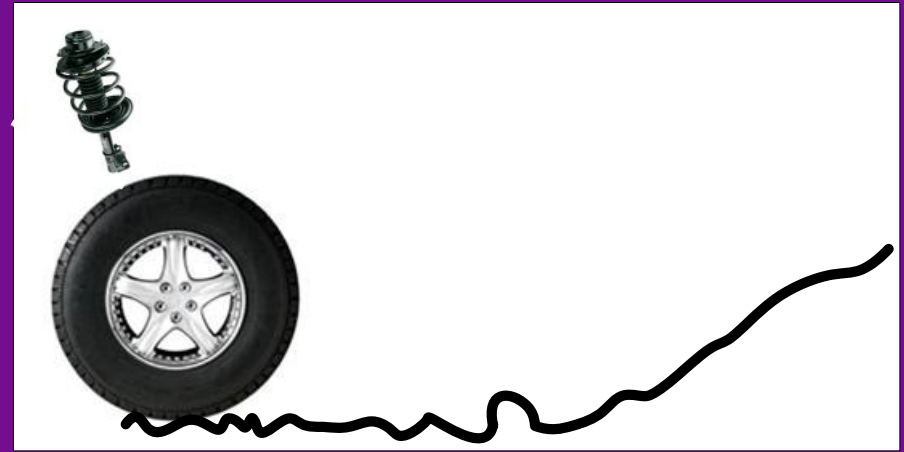

### Preserves Intelligibility

[www.StarmarkTechnologies.com](http://www.StarmarkTechnologies.com)





# *SmartAVC*<sup>™</sup> Advantages

- Only *SmartAVC*<sup>™</sup>:
  - Controls volume without sacrificing quality
  - ‘Knows’ which noises interfere with intelligibility
  - Adjusts only for persistent speech interference
  - Smooths volume fluctuations
  - Eliminates noise spikes/static bursts

[www.StarmarkTechnologies.com](http://www.StarmarkTechnologies.com)





# SmartAVC™ Functional Diagram

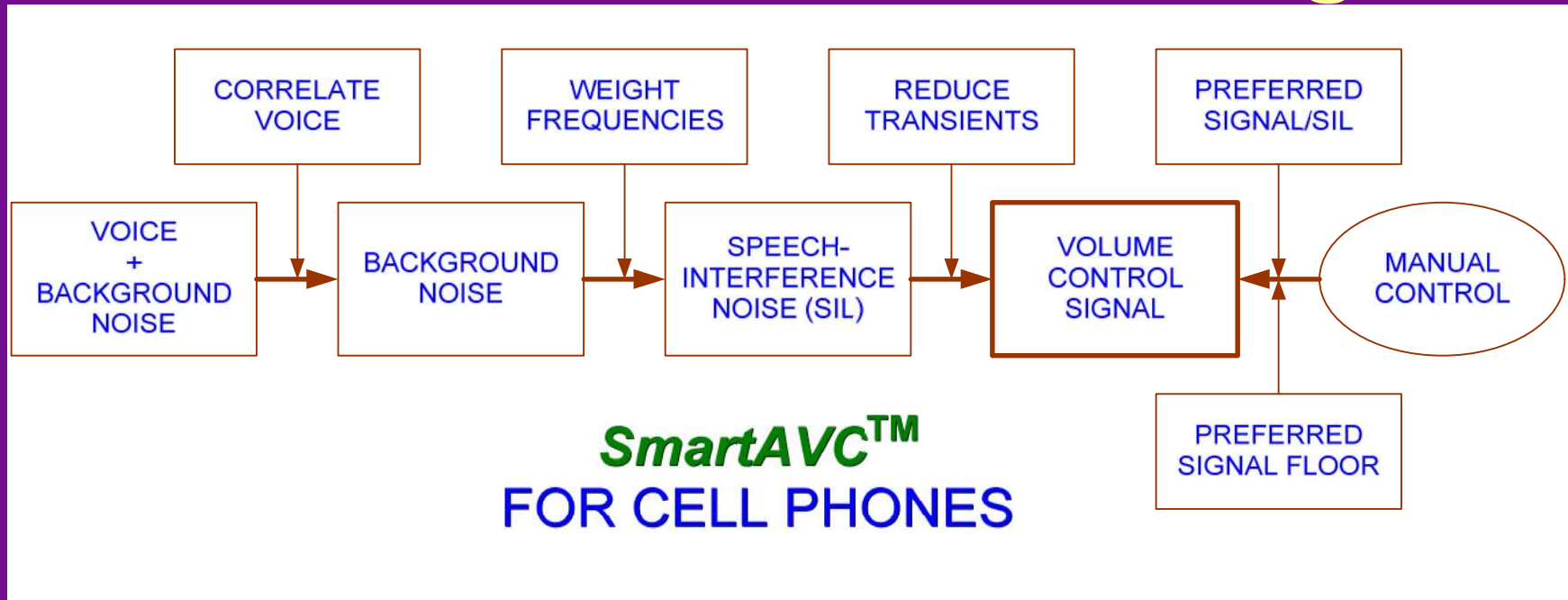

[www.StarmarkTechnologies.com](http://www.StarmarkTechnologies.com)





# SmartAVC™ Component Diagram

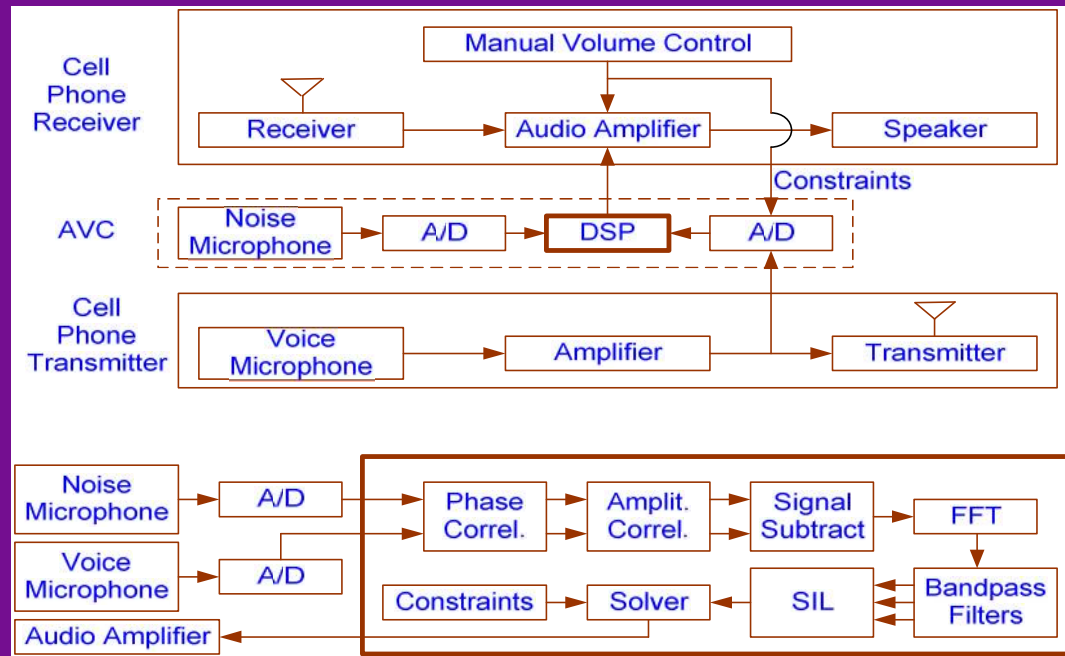

[www.StarmarkTechnologies.com](http://www.StarmarkTechnologies.com)





# SmartAVC™ Optimizes Throughput

- **SmartAVC™ response time ~ 1/4 sec**
  - Ignores transients
  - Loss ~ one syllable
  - Annoyance minimal
- **SmartAVC™ time step < 0.1(1/4 sec) ~ 1/40 sec**
  - Well-behaved integration
- **SmartAVC™ sample rate > 128(40 Hz)**

[www.StarmarkTechnologies.com](http://www.StarmarkTechnologies.com)





# SmartAVC™ Optimized for PSIL

- PSIL is average noise level in Octaves 1 – 3
- FFT optimized for calculating PSIL\*

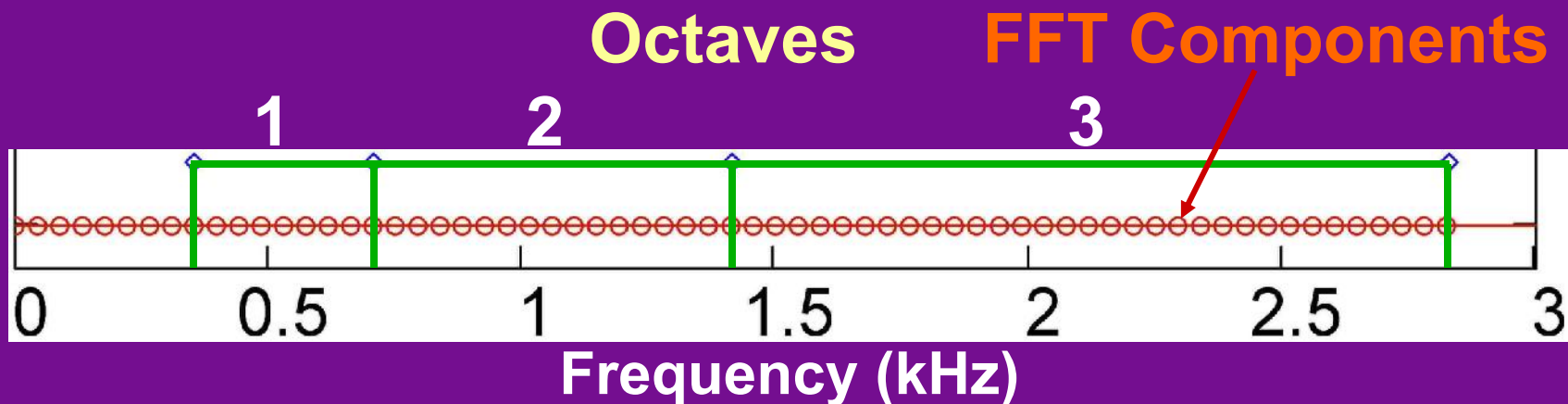

[www.StarmarkTechnologies.com](http://www.StarmarkTechnologies.com)





# SmartAVC™ Solver Algorithm

• SmartAVC™ solver algorithm ignores transient noise

$$a''(t) + b\omega_0 a'(t) + \omega_0^2 a(t) = \omega_0^2 [S(t) + R_0]$$

$$A''(t) + b\omega_0 A'(t) + \omega_0^2 [A(t) - S(t)] = 0$$

$$A'_{i+1} = A'_i + (N/s)A''_i$$

$$\text{if } |A_i - S_i| \geq r_0, \text{ then } A_{i+1} = A_i + (N/s)A'_i,$$

$$\text{otherwise } A_{i+1} = A_i$$

$$A''_{i+1} = \omega_0^2 S_{i+1} - b\omega_0 A'_{i+1} - \omega_0^2 A_{i+1}$$

$$\text{if } A_{i+1} \leq A_{\min}, \text{ then } A_{i+1} = A_{\min}$$

Normalized Equation

Solver Algorithm

[www.StarmarkTechnologies.com](http://www.StarmarkTechnologies.com)





# SmartAVC™ Ignores Transient Noise

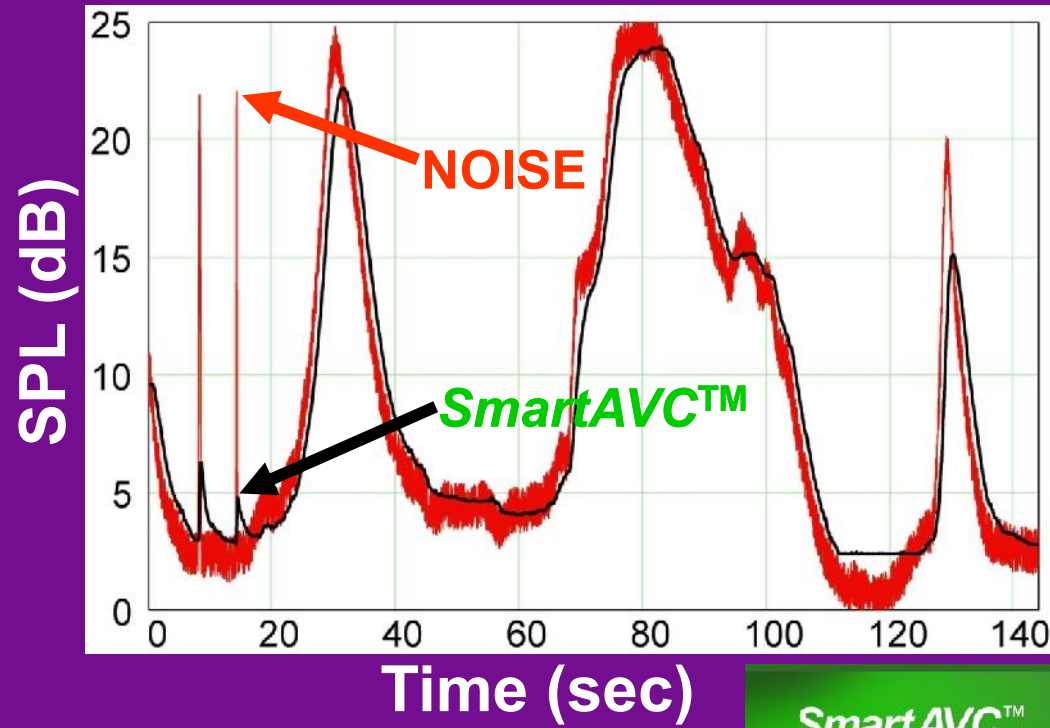

[www.StarmarkTechnologies.com](http://www.StarmarkTechnologies.com)





# SmartAVC™ Key Points

- Hearing clearly anywhere is key advantage
- Smoothly maintains constant intelligibility
- Easily implemented on handsets
  - Minimal processing, no hardware changes
- Highly leveraged way to enhance user experience

[www.StarmarkTechnologies.com](http://www.StarmarkTechnologies.com)





# SmartAVC™ Demo App

SmartAVC Demo

Welcome to the SmartAVC Demo.

Please select your desired initial volume and PSIL offset and scaling.

Use SmartAVC?

File: smartavc.mp3

Volume: [Slider]

Offset: [Slider]

Scaling: [Slider]

Start Demo

SmartAVC™ Starmark, Inc.  
<http://starmarktechnologies.com/>

Volume: 0.5  
Offset: -19.0

Android Market

Android Apps | Movies | Books | My Library

Home > Android Market > Communication

### SmartAVC™ Demo

Starmark, Inc.

SmartAVC™

★★★★★ (0)

INSTALL

Users who viewed this also viewed

**Louder Volume Hack**  
MELTUS / TOOLS  
★★★★★ (610)  
UK£1.00 (about \$1.62)

#### Description

This application is a live, interactive demonstration of SmartAVC™, the World's Smartest Automatic Volume Control(SM) for your phone and other audio devices that you use where it gets noisy.

It's easy and fun to use this app. Shout, whistle, sing, clap and make any other 'background noises' into your phone, and listen to how SmartAVC™ compensates by smoothly and gracefully adjusting the volume of the recorded voice to maintain its intelligibility. SmartAVC™ is truly an auditory luxury!

Simple directions for using this app are given at the end of this description.

Visit Developer's Website >

ABOUT THIS APP

RATING: ★★★★★

UPDATED: May 9, 2011

CURRENT VERSION: 1.0

REQUIRES ANDROID: 1.5 and up

CATEGORY: Communication

INSTALLS: 50 - 100

[www.StarmarkTechnologies.com](http://www.StarmarkTechnologies.com)

SmartAVC™

The World's Smartest Automatic Volume Control™

LEARN MORE